

2

1

B

B

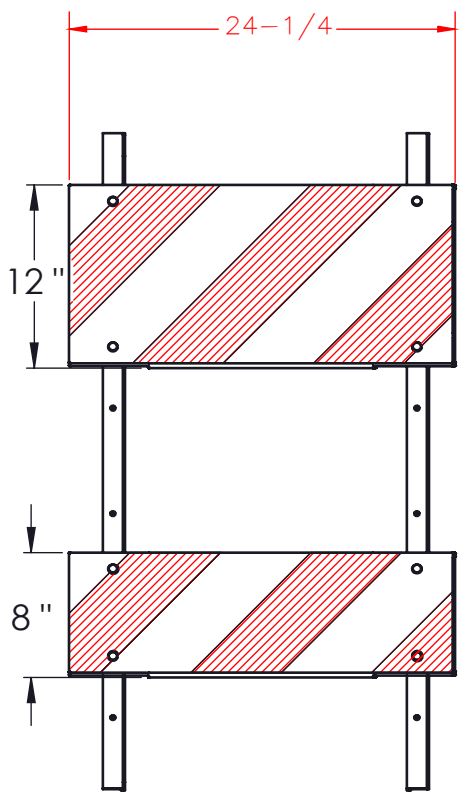

FOLDED SIZE (NOT SHOWN):  
24-1/4" X 45" X 2-5/8"

FULL 1/2" PIVOT BOLTS WITH  
NYLON INSERTED LOCKNUTS

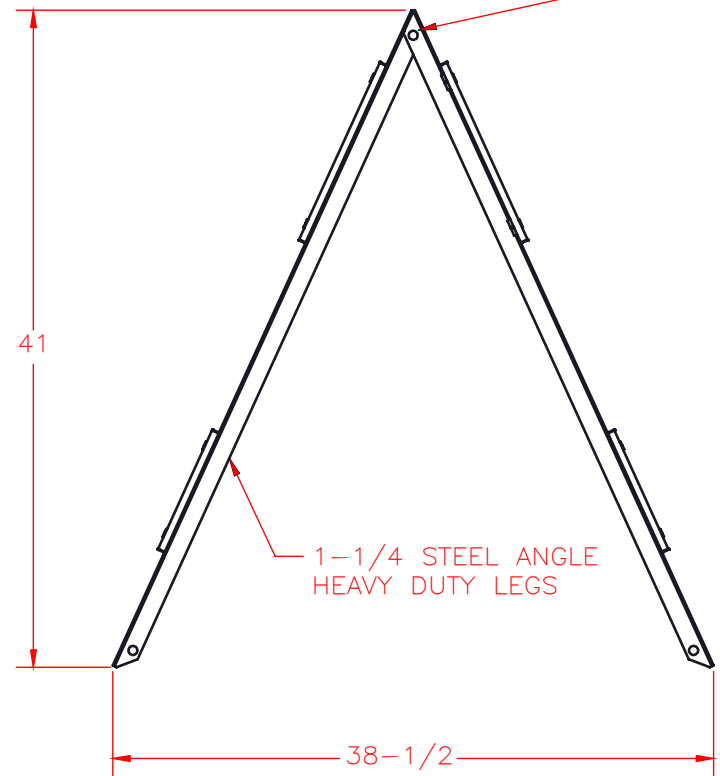

1-1/4 STEEL ANGLE  
HEAVY DUTY LEGS

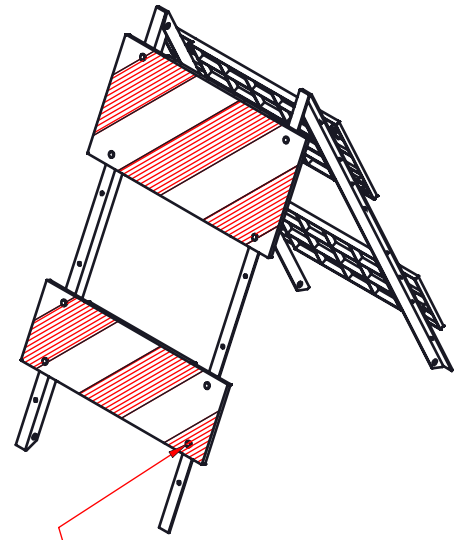

ALL FASTENERS USED ARE  
CORROSION RESISTANT

A

A

INITIAL RELEASE	07/29/03	UNLESS OTHERWISE SPECIFIED:	NAME	DATE
ORIGINAL CREATOR	J.I.L	DIMENSIONS ARE IN INCHES	DRAWN	SMB 03/09/17
 10706 W GRAND AVE. FRANKLIN PARK, ILLINOIS 60131 O:(847)455-2800 F:(847)451-7247		TOLERANCES:	CHECKED	
		FRACTIONAL ± 1/8	ENG APPR.	
		ANGULAR: BEND ±.5°	MFG APPR.	
		TWO PLACE DECIMAL ±.005	Q.A.	
		THREE PLACE DECIMAL ±.0005	<b>PROPRIETARY AND CONFIDENTIAL</b> THE INFORMATION CONTAINED IN THIS DRAWING IS THE SOLE PROPERTY OF <b>CORTINA SAFETY PRODUCTS GROUP</b> . ANY REPRODUCTION IN PART OR AS A WHOLE WITHOUT THE WRITTEN PERMISSION OF <b>CORTINA SAFETY PRODUCTS GROUP</b> IS PROHIBITED.	
		<b>MATERIAL</b>		
		LEGS: STEEL		
		PANELS: POLYOLEFIN		
		FINISH WHITE/WHITE		
		DO NOT SCALE DRAWING		



**STEELCADE TYPE II BARREL ELIMINATOR**  
 12" X 24" HIP SHEETED TOP PANEL  
 8" X 24" HIP SHEETED BOTTOM PANEL

SIZE	CSPG PART NUMBER:	REV
<b>A</b>	<b>97-03-003-02</b>	<b>1</b>
SCALE: 1:12 WEIGHT:		SHEET 2 OF 2

2

1