

**PART SPECIFICATIONS:**  
 Density = 15.600 grams per cubic inch  
 Mass = 538.432 grams  
 Volume = 36.918 cubic inches  
 Surface area = 555.690 square inches

CUSTOMER INFORMATION		UNLESS OTHERWISE SPECIFIED:		NAME	DATE
DRAWN	SMB	DIMENSIONS ARE IN INCHES	FRACTIONAL	1/16	06/05/17
CHECKED	VEB	TOLERANCES	ANGULAR BEND	±.25"	06/05/17
ENG APPR.	SMB	TWO PLACE DECIMAL	±.050		02/08/17
MFG APPR.	JMG	THREE PLACE DECIMAL	±.025		02/08/17
Q.A.	MS	INTERPRET GEOMETRIC TOLERANCING PER:			
MATERIAL: COPOLYMER PP		PROPRIETARY AND CONFIDENTIAL			
FINISH: SHEETING		THE INFORMATION CONTAINED IN THIS DRAWING IS THE SOLE PROPERTY OF THE CORTINA COMPANIES. ANY REPRODUCTION IN PART OR AS A WHOLE WITHOUT THE WRITTEN PERMISSION OF THE CORTINA COMPANIES IS PROHIBITED.			
DO NOT SCALE DRAWING		SCALE: 1:1 WEIGHT: SHEET 1 OF 3			

**Cortina**  
 Safety Products  
 10708 Grand Ave., Pleasanton, CA 94566  
 (947) 455-2000

**6 INCH STEELCADE PANEL**  
 SIZE: **D** MOLD #1459 REV: **0**  
 SCALE: 1:1 WEIGHT: SHEET 1 OF 3

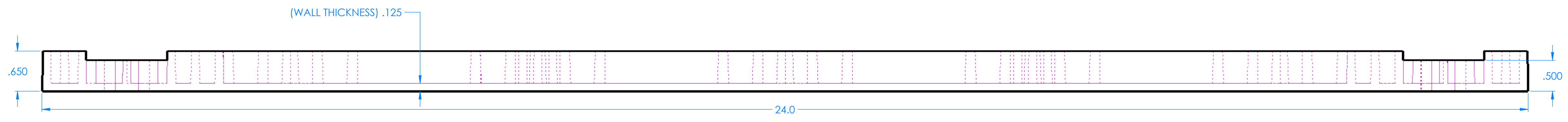
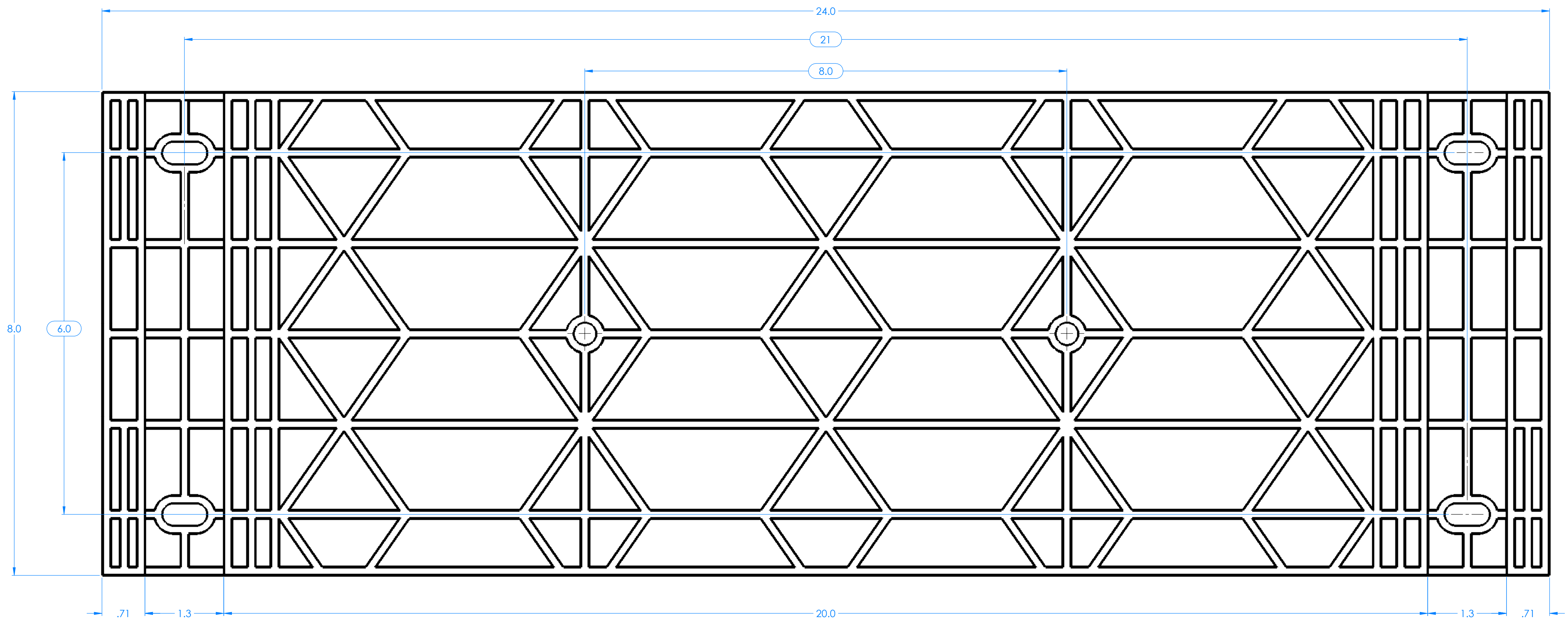

**PART SPECIFICATIONS:**  
 Density = 15.600 grams per cubic inch  
 Mass = 713.189 grams  
 Volume = 48.901 cubic inches  
 Surface area = 736.212 square inches

<b>CUSTOMER INFORMATION</b>  <small>10708 Grand Ave. Franklin Park, IL 60151 (847) 465-2000</small>		<b>UNLESS OTHERWISE SPECIFIED:</b> DIMENSIONS ARE IN INCHES TOLERANCES: FRACTIONAL: 1/16 ANGULAR: BEND ±.25° TWO PLACE DECIMAL ±.020 THREE PLACE DECIMAL ±.025		NAME: SMB DATE: 06/05/17	 <b>8 INCH STEELCADE PANEL</b>
DRAWN: SMB CHECKED: VEB ENG APPR: SMB MFG APPR: JMG	DATE: 06/05/17 02/08/17 02/08/17	Q.A.: MS INTERPRET GEOMETRIC TOLERANCING PER: MTS MATERIAL: COPOLYMER PP FINISH: SHEETING <small>DO NOT SCALE DRAWING</small>	PROPRIETARY AND CONFIDENTIAL <small>THE INFORMATION CONTAINED IN THIS DRAWING IS THE SOLE PROPERTY OF THE CORTINA COMPANIES. ANY REPRODUCTION IN PART OR AS A WHOLE WITHOUT THE WRITTEN PERMISSION OF THE CORTINA COMPANIES IS PROHIBITED.</small>	SIZE: <b>D</b> MOLD #1459 SCALE: 1:1 WEIGHT:	

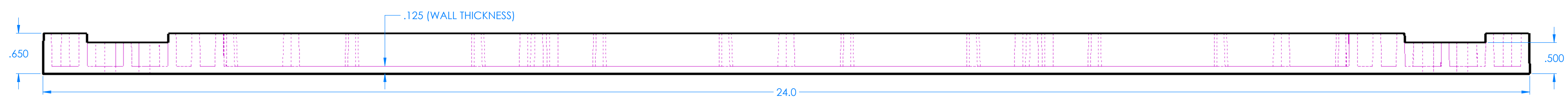
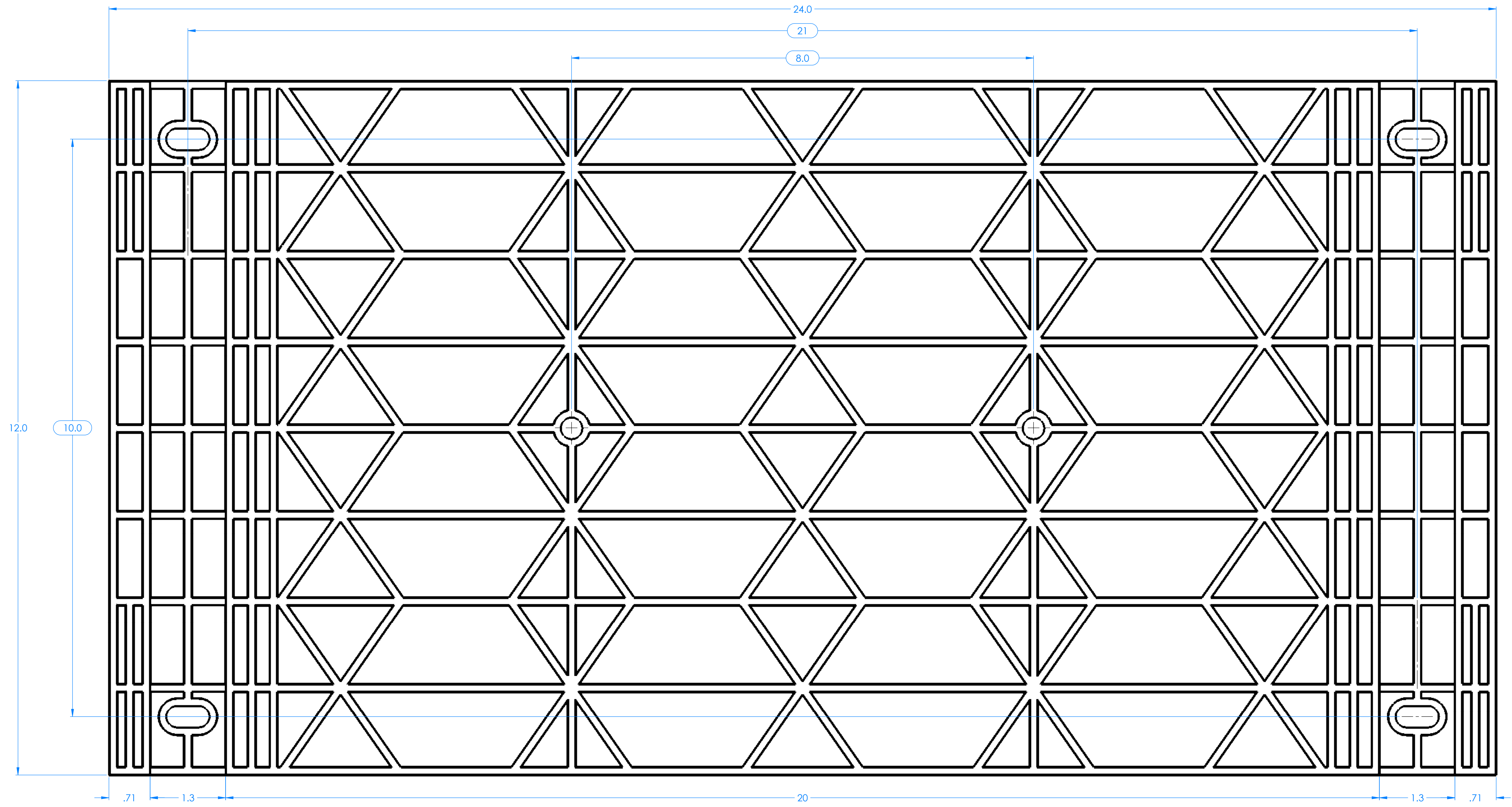

**PART SPECIFICATIONS:**  
 Density = 15.600 grams per cubic inch  
 Mass = 1037.911 grams  
 Volume = 71.165 cubic inches  
 Surface area = 1071.957 square inches

		<b>CUSTOMER INFORMATION</b> 10708 Grand Ave., Pleasanton, CA 94566 (925) 465-2000		<b>UNLESS OTHERWISE SPECIFIED:</b> DIMENSIONS ARE IN INCHES TOLERANCES: FRACTIONAL: 1/16 ANGULAR: BEND ±.25° TWO PLACE DECIMAL ±.020 THREE PLACE DECIMAL ±.005		NAME: SMB DATE: 06/05/17 DRAWN: VEB CHECKED: VEB ENG APPR.: JMG MFG APPR.: JMG Q.A.: MS					
MATERIAL: COPOLYMER PP FINISH: SHEETING DO NOT SCALE DRAWING				PROPRIETARY AND CONFIDENTIAL THE INFORMATION CONTAINED IN THIS DRAWING IS THE SOLE PROPERTY OF THE CORTINA COMPANIES. ANY REPRODUCTION IN PART OR AS A WHOLE WITHOUT THE WRITTEN PERMISSION OF THE CORTINA COMPANIES IS PROHIBITED.				12 INCH STEELCADE PANEL SIZE: <b>D</b> SCALE: 1:1 WEIGHT:		MOLD #1459 REV: <b>0</b> SHEET 3 OF 3	