

FOLDED SIZE (NOT SHOWN):
24-1/4" X 45" X 2-5/8"

FULL 1/2" PIVOT BOLTS WITH
NYLON INSERTED LOCKNUTS

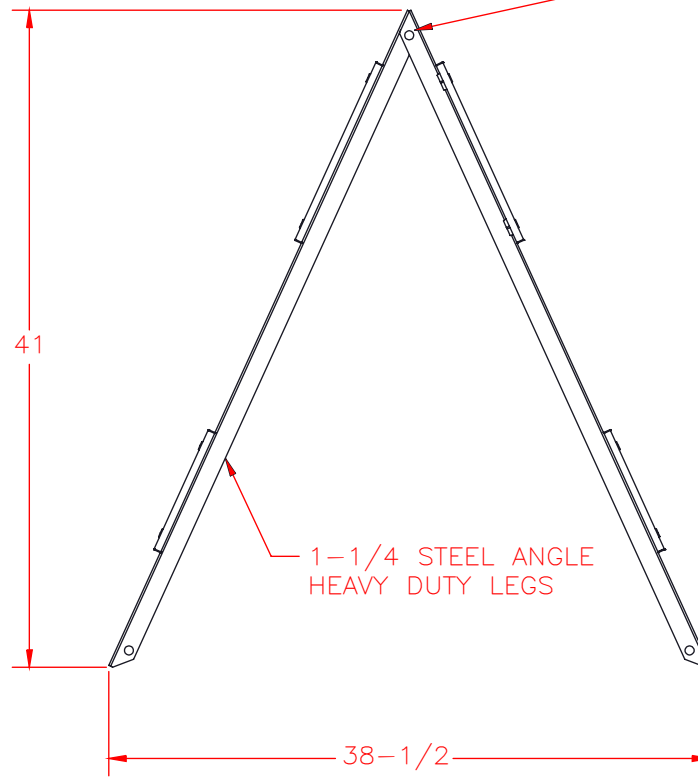

1-1/4 STEEL ANGLE
HEAVY DUTY LEGS

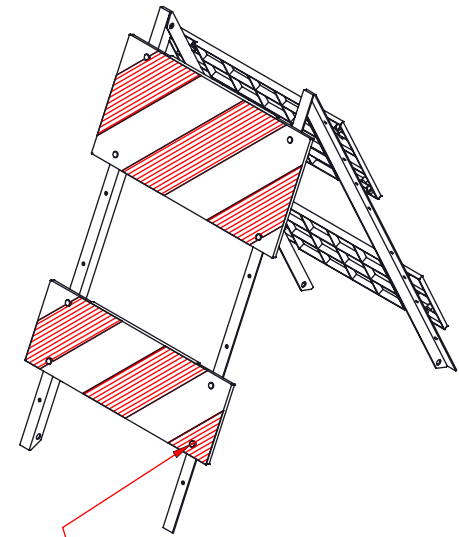

ALL FASTENERS USED ARE
CORROSION RESISTANT

01	----	INITIAL RELEASE	JIL	7-29-2003
REV	REF	REVISION DESCRIPTION	BY	DATE

MATERIAL
LEGS - STEEL
PANELS - POLYOLEFIN

COLOR AND FINISH
WHITE / WHITE



2 PL. DECIMALS ± N/A
3 PL. DECIMALS ± N/A
ANGLES ± N/A

THIS DRAWING IN DESIGN & DETAIL IS THE PROPERTY OF CORTINA TOOL & MOLDING COMPANY. MATERIAL DESCRIBED & INFORMATION CONVEYED MAY NOT BE COPIED, DIVULGED OR USED FOR MANUFACTURING WITHOUT CONSENT. ALL DESIGN AND INVENTION RIGHTS RESERVED.

CTM Cortina Tool & Molding Co.
10706 WEST GRAND AVENUE, FRANKLIN PARK, IL 60131

STEELECADE TYPE II BARREL ELIMINATOR
12 X 24 EGR SHEETED TOP PANEL
8 X 24 EGR SHEETED BOTTOM PANEL

SCALE AT A	SIZE 1 = 12	DRAWING NUMBER	REVISION
DRAFTER JIL	DATE 7-29-2003	97-03-003-01	01
CHECKER	DATE		