

BOTTOM FLANGE

NOTES

1. ENGINEERING GRADE REFLECTIVE STRIPES PERMANENTLY FIXED TO THE DRUM
2. PECULIAR SPACING MEETS FED'L SPECS
3. SEMI-HEXAGONAL BOTTOM FLANGE REDUCES ROLLING IN HIGH WINDS
4. RECYCLED RUBBER MOLDED BASE AVAILABLE IN 25 OR 40 LBS
5. LOWER COST ALTERNATE IS THE 22.5 LB RECYCLED TIRE RING

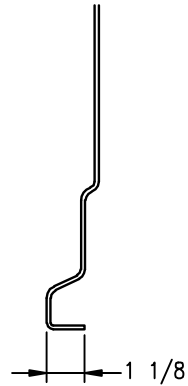

IN-TURNED BOTTOM LIP MUCH STRONGER THAN OTHER DRUMS

DOUBLE REINFORCED BOLT HOLES FOR BARRICADE LIGHTS
 TWO FLAT, LEVEL SHELVES HELP PROTECT THE LIGHTS
 HUGE GRAB HOLE FOR QUICK AND EASY DEPLOYMENT AND RETRIEVAL

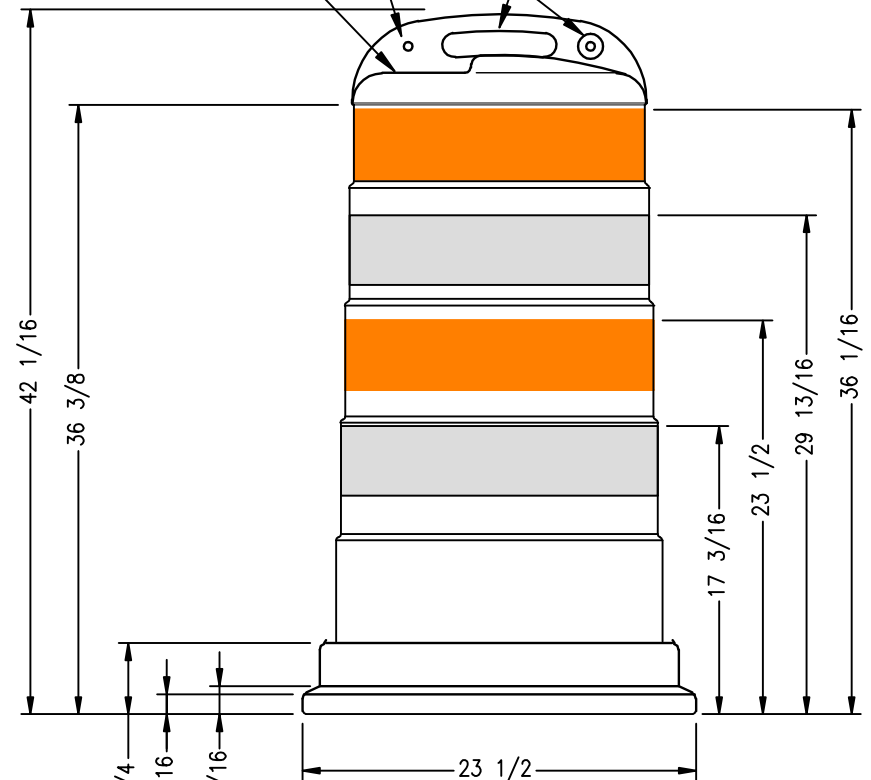

FRONT VIEW

CHANNELIZER DRUMS ARE CERTIFIED TO BE IN COMPLIANCE WITH NCHRP PART 350

REV	REF	REVISION DESCRIPTION	BY	DATE
A	---	INITIAL PRODUCT RELEASE FOR SALES REPS AND CUSTOMER SERVICE	JIL	7-17-2015
MATERIAL		COLOR AND FINISH	THIRD ANGLE PROJECTION	
MOLDED OF DURABLE POLYOLEFIN BLENDED WITH UV INHIBITORS		MOLDED DRUM - ORANGE WEIGHT = 8.0 LB		
TOLERANCES UNLESS OTHERWISE SPECIFIED		2 PLACE DECIMALS ± N/A 3 PLACE DECIMALS ± N/A ANGULAR DIMENSIONS ± N/A		
<small>THIS DRAWING IN DESIGN AND DETAIL IS THE PROPERTY OF CORTINA TOOL & MOLDING COMPANY. MATERIAL DESCRIBED AND INFORMATION CONVEYED MAY NOT BE COPIED, DIVULGED TO OTHERS OR USED FOR MANUFACTURING OR ANY OTHER PURPOSE WITHOUT CONSENT. ALL DESIGN AND INVENTION RIGHTS RESERVED.</small>				

Cortina A Cortina Company
 REGISTERED 15099000
 www.cortinaco.com
 10706 WEST GRAND AVENUE, FRANKLIN PARK, IL 60131

TRAILBOSS CHANNELIZER DRUM
 WITH 4" ENGINEERING GRADE STRIPING-OWOW
 CONFORMS TO ALL MUTCD REQUIREMENTS

SCALE AT B SIZE	NTS	DRAWING NUMBER	REVISION
DRAFTER JIL	DATE 7-17-2015	03-780-4EG	A
CHECKER MK	DATE 7-17-2015		